

TECHNICAL SHEET

FLECK
TWIN VALVE SERIE 9500

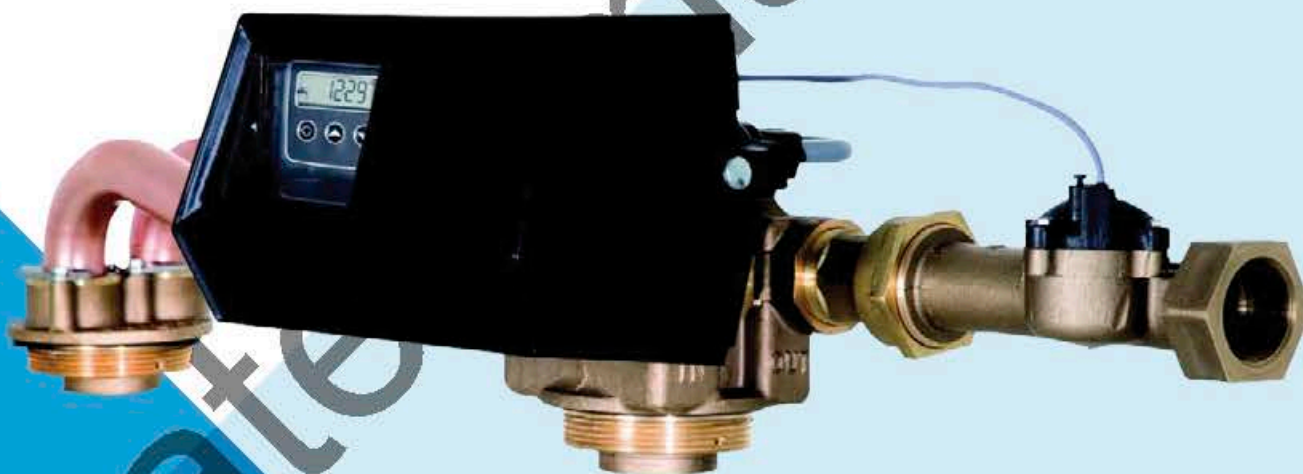

TECHNICAL SHEET



FLECK VALVE TWIN SERIE 9500

TECHNICAL CHARACTERISTICS

- Continuous soft water provision, with one tank in use, the second being in regeneration or stand-by
- Regeneration with softened water
- Valve body in brass (allows the use of hot water (up to 65°C))
- Adjustable cycles
- Fast connection of the second tank (to be ordered separately)



VALVE SPECIFICATION

Material	Brass
Hydrostatic pressure	20 bar
Working pressure	1.8 - 8.5 bar
Working temperature	1 - 43 °C
Electrical rating	24 V / 50 or 60 Hz, other upon request
Protection index	IP 22
Certificates	2004/108/CE, Electromagnetic compatibility 2006/95/CE, Low voltage D.M. 174/04, Italian norm

FLOW RATE (3.5 BAR INLET - VALVE ALONE)

	1 1/2"
Continuous ($\Delta p = 1$ bar)	8.4 m ³ /h
Peak ($\Delta p = 1.8$ bar)	11.2 m ³ /h
CV*	9.8 gpm
Maximum backwash ($\Delta p = 1.8$ bar)	3.3 m ³ /h

* Cv: Flow rate of valve alone in gpm at 0.07 bar pressure drop.

DOWN FLOW REGENERATION

	Mechanical	Electronic
Cycles	Adjustable	Adjustable
Time available	164 min	199 min each cycle

CONNECTIONS - DIMENSION

Inlet / outlet	1 ½" BSP
Distributor tube	50 mm (DN40)
Drain line	1" NPT
Brine line 1600	¾"
Brine line 1710	1"
Mounting base - Top	4" - 8 NPSM
Height (from top of tank)	185 mm
Tank size application (recommended)	
Water softener	6 - 24" (150 - 610 mm)

METER

	Mechanical
Accuracy range (± 5%)	5 - 283 Lpm
Standard capacity range	2.4 - 40 m³
Extended capacity range	12 - 200 m³

REGENERATION CYCLES

Down flow

- 1) Backwash (Upflow)
- 2) Brine & slow rinse (Down flow)
- 3) Rapid rinse (Down flow)
- 4) Brine tank refill
- 5) Service

OPTIONS

Electronic	ET, SXT
Hot water (only mechanical)	65°C

DIMENSIONS

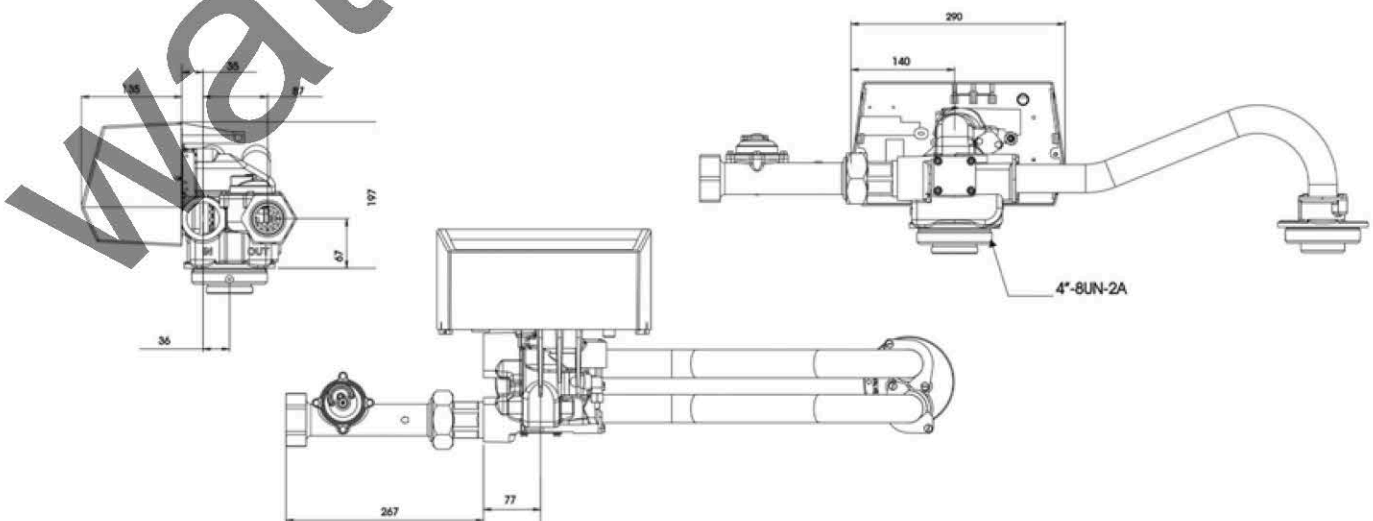

watersmarket.ru

www.pentiraquaeurope.com